

babyplast

The System



The micro injection moulding machine



The ideal machine for the
production of micro parts
Suitable for all types of *thermoplastic materials* up to 420° (PEEK),
metals (MIM), ceramic (CIM), wax.

Micro-injection moulding machine 6/10P

Maximum performance minimum space

The smallest but greatest

Babyplast 6/10P is one of the smallest, fully hydraulic, injection moulding machines. Thanks to the unique concept of the machine platens which act as mould bolsters, the cost and dimensions of the moulds are reduced considerably. Babyplast 6/10P occupies less than 0,6m² of floor space and is extremely quiet (< 68dB)

Precision

Babyplast 6/10P Guarantees the highest precision thanks to the injection piston and pre-plastification of the material.

To obtain the optimum volume of material, there are 5 interchangeable pistons available. It is also possible to move the injection unit off centre.



User friendly

- Touch screen colour display.
- Easy to consult pages and user friendly display
- Handles and stores over 100 tool settings
- Back-up on USB memory drive
- Record of last 20 cycles
- Ethernet connections: modbus TCP

Standard mould parts



Rotating table for 2 shot applications

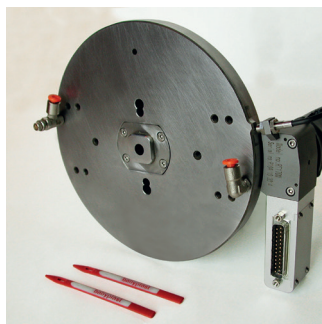

Fixed platen

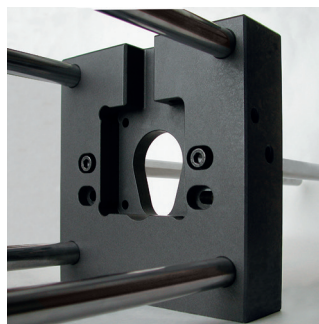

The difference between Babyplast (left) conventional (right)

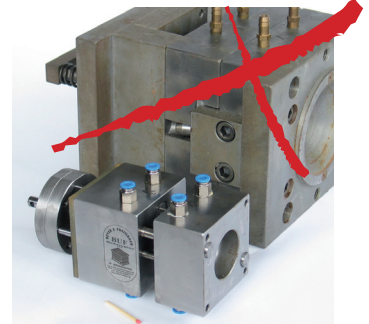



Applications:

- Production of small precision parts
- Long and short production runs
- Laboratory tests / sample production
- Prototyping
- Medical products / clean room applications
- Technical training

Machine with accessories

- Bench
- Chiller
- Drier
- De-humidifier
- Temperature controller max. 90°C.
- Sprue separator

Foot print of only 0,7 mq.



Included:

- Quality control (Cycle time/cushion/injection time/injection pressure)
- Automatic shut down in case of alarm
- De-compression
- Two injection pressures
- Possibility for off centre injection
- Temperature tolerance band
- PID temperature control
- Stand-by temperature
- Speed control on all movements
- Mould safety
- 2 clamp speeds
- Central ejector with up to 9 strokes
- Speed and pressure control on ejector
- Removable tie bars
- Ejector return sensor
- Easy to consult pages and user friendly display
- Multi-lingual
- Handles and stores over 100 tool settings
- Part counter – settings for production batches
- Integrated 4 zone cooling water manifold
- USB socket
- Intrusion programme
- Hour meter
- Sprue break
- Injection and clamp positions monitored via transducers
- Electronic transducer for pressure control
- Inverter for motor speed control
- Colour touch screen display.
- 4th zone for mould temperature control
- Machine platens act as bolsters to reduce costs and time for mould construction
- Outputs for core pull

Optional:

- Mixer nozzle (static mixer)
- Euromap 67
- Accumulator for injection speed.
- Shut off nozzle
- Nozzle with tip for injecting directly into part.
- 5th mould heater zone
- Hydraulic or pneumatic core pull
- Ethernet modbus
- Interface for second injection unit for 2 shot applications
- LSR injection unit
- Rotating table
- Air blow
- Cooling ring for moving platen
- Special spec. For high temperature materials
- Hot runners

Accessories:

- Bench with space for chiller
- Drier
- Loader for plastic materials (electric or Venturi)
- Temperature controller for moulds
- Sprue separator
- Electrical cabinet for accessories
- Set of drawers for moulds
- Reject part separator
- Sprue picker

The difference:



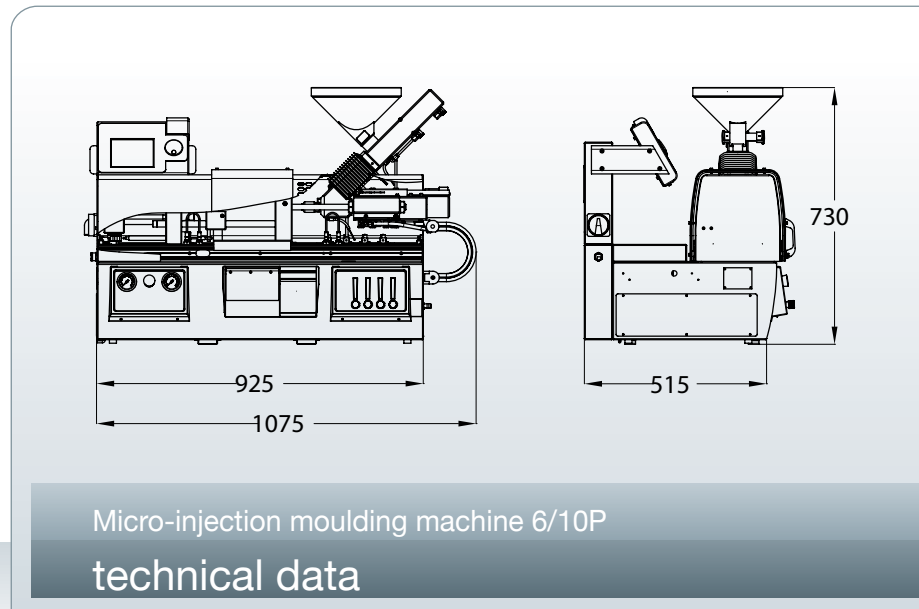

Micro-injection moulding machine 6/10P
technical data

Dimensions of machine platens

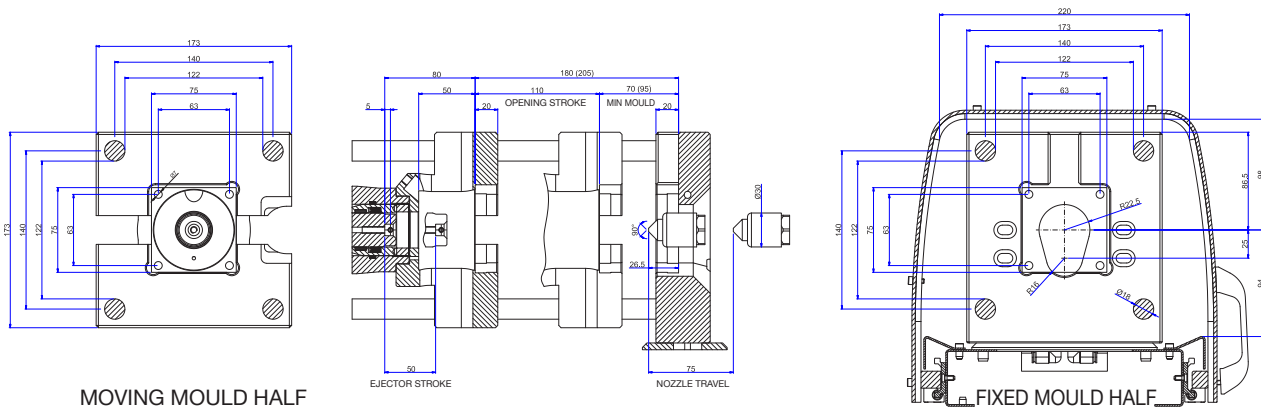

Mould dimensions

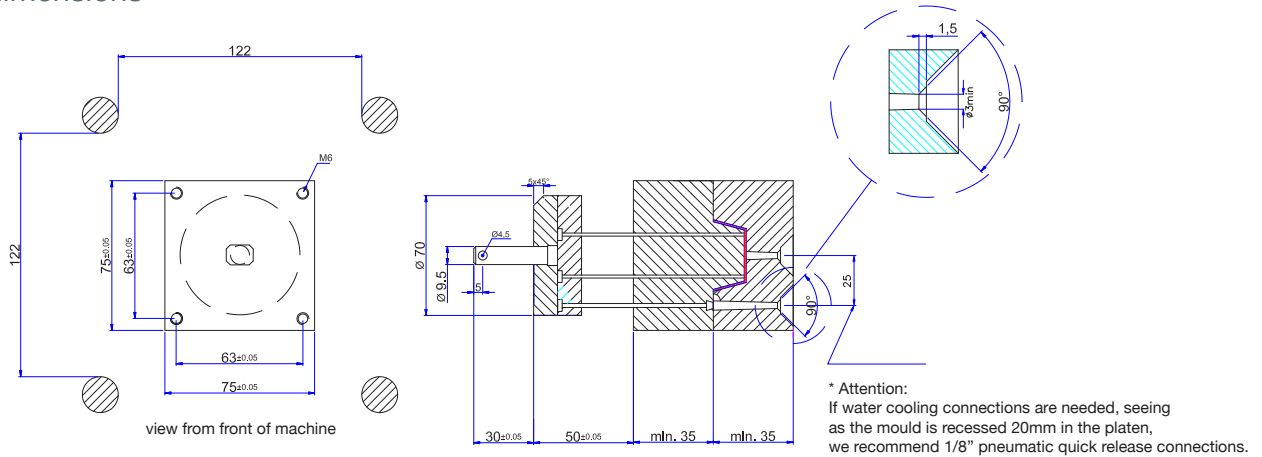

Piston diameter (mm):	10	12	14	16	18
Injection volume (cm ³):	4	6,5	9	12	15
Injection pressure (bar):	2035	1850	1340	1030	815
Clamping force:	62 kN				
Opening stroke:	110 mm				
Ejector force:	7,5 kN				
Ejector stroke:	50 mm				
Oil tank capacity:	15 L				
Power consumption:	3 kW				

Weight:	150 kg
Min. Mould dimensions:	75 x 75 x 70 mm
Alimentation:	3~400V 50/60Hz + Neutral + earth
	3~230V 50/60Hz + earth
	1~230V 50/60Hz + earth
Hydraulic pressure:	130 bar
Dry cycle:	2.4 sec
Noise level:	<70 db